

SPECIFICATIONS

Rated(额定参数): 300V,15A  
 Dielectric strength(抗电强度): AC2000V/1 Minute  
 Insulation Resistance(绝缘电阻):1000MΩ Min  
 Contact Resistance(接触电阻):20mΩ Max  
 Screw Torque(扭矩): 0.4Nm (3.5Lb.in)  
 Wire Range(线径):26~14AWG  
 Strip length(剥线长度):6~7mm  
 Temp. range(操作温度): -40°C~+105°C  
 MAX Soldering(瞬时温度):+250°C,5s  
 IEC Standard

Pollution degree	2	2	3
Overvoltage category	II	III	III
Rate impulse voltage(KV)	2.5KV	2.5KV	2.5KV
Rate voltage(V)	250V	250V	250V
Rate current(A)	18A		

Housing Material(塑件): PA66 (UL94 V-0)  
 Contact(端子): Brass, Tin plating(黄铜镀锡)  
 Clamp(方块): Brass/Steel(铜/铁), Ni plating(镀镍)  
 Screw (螺丝): M2.5, Steel, Zinc plating(钢,镀锌)

PITCH RANGE IN MM			NOMINAL DIMENSION RANGE IN MM				
TO	OVER	OVER	TO	OVER	OVER	OVER	OVER
6	6	10	30	30	60	100	150
	TO	TO	TO	TO	TO	TO	TO
	10	24	60	100	150		
±0.10	±0.15	±0.25	±0.30	±0.30	±0.50	±0.70	±1.00

Ordering Information

JL 500 - 500 XX G 0 1

Pitch  
500=5.0PH

No.of pins  
2P,3P,4P~24P

Housing Color  
 B=Black  
 G=Green  
 U=Blue  
 R=Red  
 W=White  
 Y=Yellow  
 O=Orange  
 E=Grey

Packing  
 0=Pe bag  
 A=Tray  
 T=Tube

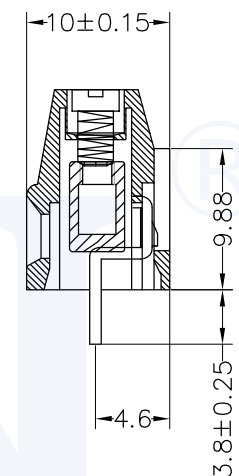
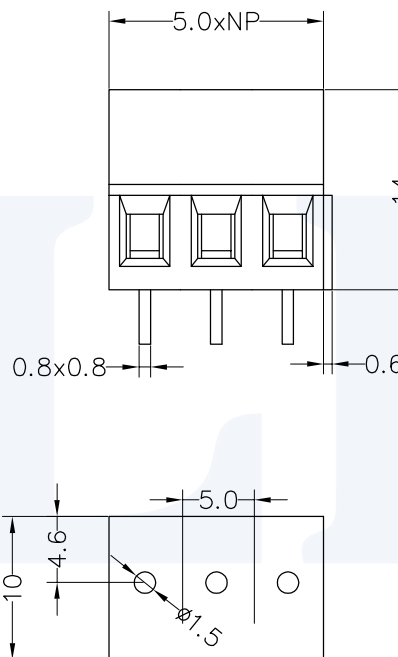
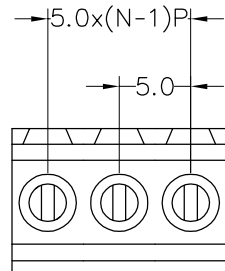

Recommended P.C.B Layout(Top Side)

DRAW	SHUANGPING ZHENG	SCALE	FIT	东莞市锦凌电子有限公司 DONGGUAN JINLING ELECTRONIC CO.,LTD	
		UNIT	mm		
CHECK	LICHAO LIU	SIZE	A4		
		SHEET	1/1		
APPROVE	YONGLIANG GAO	PROJ.		PART NO.	JL500-500XXG01
				TITLE:	JL500-5.0-XXP螺钉式/绿色