

HSF RoHS

Note:

Current Rating: POWER CONTACT 7A ma.
 BRAKE CONTACT 1A ma.
 Voltage Rating: POWER CONTACT 200 VAC.
 BRAKE CONTACT 100 VAC.
 Insulation Resistance:>1000 MΩ at @500VDC
 Withstand Voltage:1500VAC for 1 minute
 Operation Temperature:-40°C to +105°C

applicable Cable:

Power Contact AWG#18 to #20
 Coated outer dia:1.8 to 2.0 dia
 Brake Contact AWG#24 to #22
 Coated outer dia:1.1 to 1.4 dia
 Cable outer dia: 6.0 to 6.5 dia

Contact Material:Brass
 Contact Plating:Au or Sn Over Ni
 Insulator Material:PBT (UL94V-0) Black

- M2螺丝要求对应使用1#螺丝刀头。
- 破坏扭力为0.3 N.m(Max), 建议使用扭力0.15 ±0.015N.m.

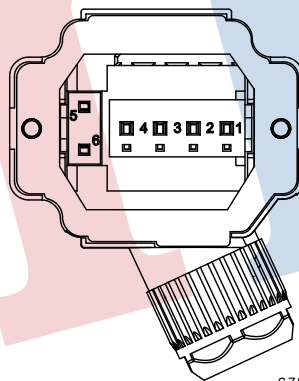
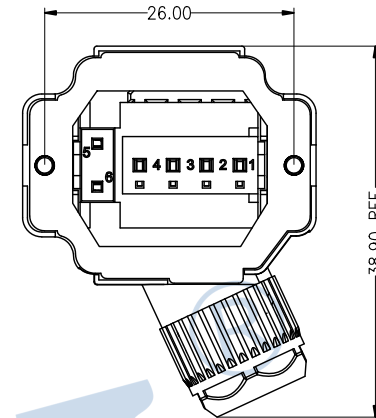
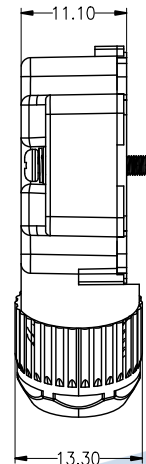
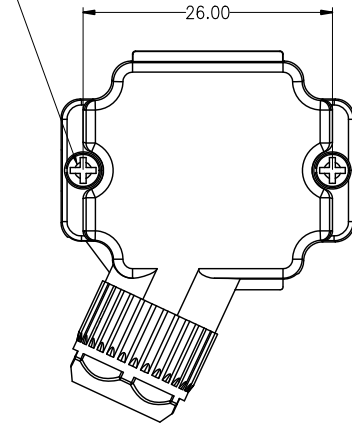

6353A-06S-A0-N00

反向出线样式

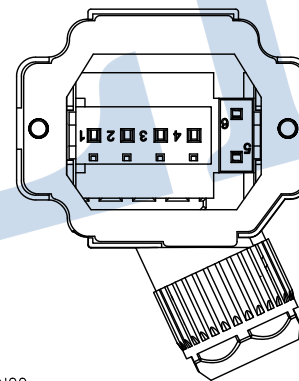

6353A-06S-A0-N01

正向出线样式

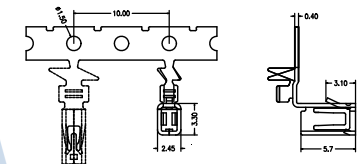

端子需单独购买
 产品用量: 4pcs
 端子料号: 202. 6353A0102P01
 包装数量: 2000pcs/盘

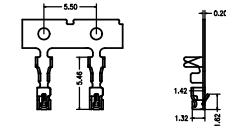

端子需单独购买
 产品用量: 2pcs
 端子料号: 202. 6353A0202P01
 包装数量: 1000pcs/盘

NO.	NAME	Q'TY	DESCRIPTION
1	Outside shell(外壳)	1	Black
2	Housing(主体)	1	Black
3	Shrapnel(弹片)	2	
4	Shim(垫片)	1	Black(Ø21*11)
5	Stopper(塞条)	1	Black
6	Nut(螺母)	1	Black
7	Waterproof ring(防水圈)	1	Black(Ø8.5*5.5)
8	Screw(螺丝)	2	M2*12
9	Locking ring(锁环)	1	
10	Tailclip(尾夹)	1	
11	Brake Contact	2	Plating Gold
12	Power Contact	4	Plating Gold

NO.	DATE	MODIFICATION DESCRIPTION	CHANGE	OPERATION		DRAW	Jelly Feng	23.03.13	SCALE	FIT
				X.X	±0.30					
				X.XX	±0.20	CHECK			UNIT	mm
				X.XXX	±0.10	APPROVE			SIZE	A4
A0	2023.03.13	NEW DRAWING		Angle	±3°				SHEET	1/2
REV	DATE	MODIFICATION DESCRIPTION	CHANGE	DIM	TOL				PROJ.	☉

JILN 深圳市锦凌电子有限公司
 SHENZHEN JINLING ELECTRONICS CO.,LTD
 Tel: 86-755-27483253 Fax: 86-755-2997-5588

PART NO. 6353A-06S-A0-N00

TITLE: 微型电机动插头 4+2P