



**SPECIFICATIONS**

Rated Current:2.0AMP  
 Contact Resistance:20mΩ Max  
 Withstand Voltage:500V AC/DC  
 Insulation Resistance:1000MΩ Min  
 Operation Temperature:-40°C to +105°C

Contact Material:Brass  
 Contact Plating:Au Over Ni  
 Insulator Material:Polyester(UL94V-0)  
 Resistance To Soldering Heat:  
 260° C±5° C, 10s(PA6T&PA9T&LCP insulator)

Recommended P.C.B Layout(Top Side)  
 (PCB BOARD TOLERANCE±0.05)

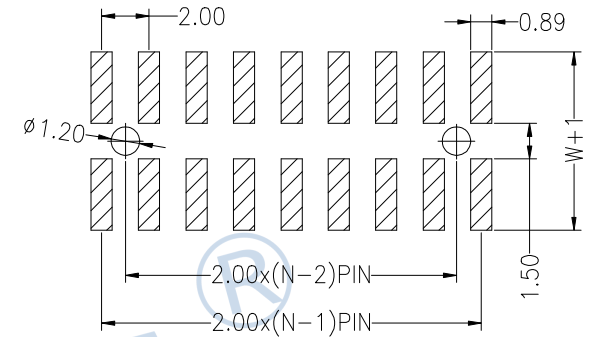
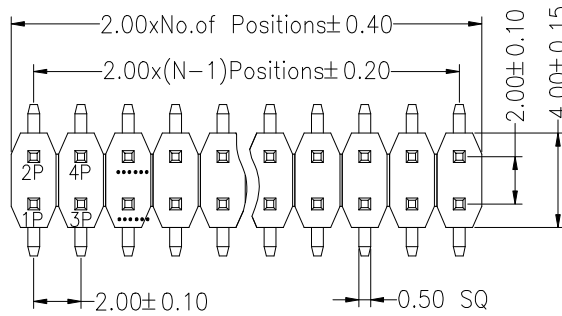

**Ordering Information**

**13XX 12 XX X X XX M XXX X 0X**

- High.of Plastic: 10=H1.0mm, 15=H1.5mm, 20=H2.0mm, 25=H2.5mm, 30=H3.0mm
- No.of Pins Per Row: 02~40P
- Insulator Material Option: C=BK-PA6T, E=BK-PA9T, F=BK-LCP
- Post: W=With Post, N=W/O Post
- Contact Plating: G0:Gold Flash, G1:1u" Gold, G2:1.5u" Gold, G3:2u" Gold, G4:3u" Gold, G5:5u" Gold, G6:10u" Gold, G7:15u" Gold, G8:30u" Gold, S0:Gold Flash/Tin, SN:Tin
- Pin Length
- Packing: 0=PE Bag, A=Tray, T=Tube, P=Tube+Cap, R=Reel+Cap, M=Reel+Mylar

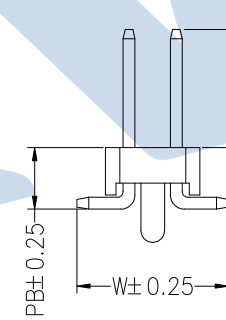
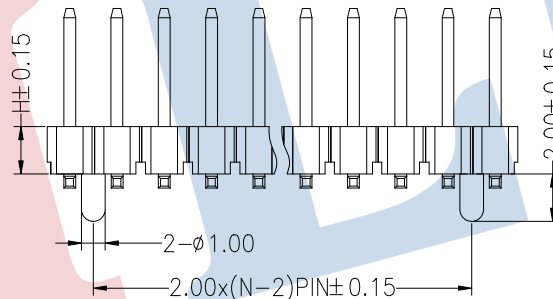

W=With Post

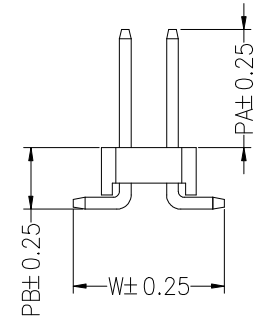

N=W/O Post

Dimension antitheses list			
ITEM	PA	PB	W
Alternate	XXX	XXX	XXX

		OPERATION		DRAW	RICH LIN	23.06.10	SCALE	FIT
		X.X	±0.30					
		X.XX	±0.20	CHECK			UNIT	mm
		X.XXX	±0.10				SIZE	A4
A0	2023.06.10	NEW DRAWING		APPROVE			SHEET	1/1
REV	DATE	MODIFICATION DESCRIPTION	CHANGE				PROJ.	◆

**JILN** 深圳市锦凌电子有限公司  
 SHENZHEN JINLING ELECTRONICS CO.,LTD  
 Tel: 86-755-27483253 Fax: 86-755-2997-5992

PART NO. 13XX12XXXXXXMXXX0X  
 TITLE: 2.0mm Pin Header SMT